



POLYPRO® AH-160 ROOF TILE ADHESIVE INSTALLATION INSTRUCTIONS

UNDERLAYMENTS

POLYPRO® AH-160 Roof Tile Adhesive will adhere to any granulated mineral surfaced roll roofing meeting ASTM D6380. The roof tile adhesive will also adhere to modified bitumen products. These types of products are usually more critical when determining resistance values, due to the percentage of modifiers and the effect the modifiers contribute to the softening of the top surface when exposed to elevated temperatures. **Products surfaced with polypropylene or silicone based surfaces are not recommended. Please refer to our website for the most current approved underlayment list.**

UNDERLAYMENT ATTACHMENT

Since the roof components are being adhered to the top surface of the underlayment system, consideration must be made for the attachment of the underlayment to the substrate. Polyfoam Products, Inc. lists the most commonly used attachment systems in our evaluation or compliance reports. Please contact Polyfoam Products, Inc. for attachment recommendations in your area.

Nailable Wood Decks - Attachment of the underlayment system to nailable decks can be calculated mathematically and is dependent on various factors which range from the type of fastener, the diameter of the fastener, the type of substrate, fastener density, pull over value of the fastener head through the underlayment, mean roof height, basic wind speed etc. Our ICC-ES Evaluation report list the fastener density pattern for the various basic wind speed used in the United States

Non-nailable Decks - Typically these types of decks are usually primed, and the waterproofing is accomplished with self-adhered membranes, cold process systems or applied with hot asphalt, modified acrylics, Elastomeric type products or to raw concrete.

FLASHINGS

Apply the flashing material according to the tile manufacturers recommendations, Tile Roofing Institute (TRI)/ Western States Roofing Contractors Association (WSRCA) "Concrete and Clay Roof Tile Installation Manual for Moderate Climate Regions, FRSA/TRI "Concrete and Clay Roof Tile Installation Manual" (System 4), Florida Building Code RAS 120 or local code requirements.

CONCRETE AND CLAY ROOF TILES

POLYPRO® AH-160 will adhere to clay and concrete roof tile as well as other roof components. Be sure the clay tiles are not dipped in silicon used to inhibit the formation of mold and mildew on the clay tiles.

TOTAL RESISTANCE VALUES

Polyfoam Products, Inc. provides different paddy placements to meet the wind design pressures for various mean roof heights as well as, basic wind speeds. Polyfoam Products has the highest total resistance values of any currently approved attachment system including mortar, nails, nails and hurricane clips and/or screws with no (or minimal, depending on the pitch of the roof) penetrations through the waterproofing underlayment. For specialty jobs please contact Polyfoam Products, Inc. **Note: Refer to product approval or evaluation report to verify approved paddy placements for your region.**

ADDITIONAL ATTACHMENT REQUIREMENTS

Additional fastening may be necessary on steep pitches to hold the tiles in place until the adhesive has a chance to cure. The fastening requirements are as follows:

For flat/low, medium, and high profile tiles, for slopes above 6":12" up to and including 7":12", fasten every tile in the first course and every third tile of the fifth course in addition to the tile adhesive. **Note: Some code bodies may require the eave tiles to be fastened at lower slopes.** For slopes above 7":12" fasten every tile in addition to the tile adhesive. Apply compatible flashing cement to seal all fastener penetrations where required. **Note: When utilizing tiles manufactured with batten lugs, the tiles may be engaged over battens, additional fastening of tile is not required.**

As an alternate to nailing every tile, for tiles designed with batten lugs only, tiles may be engaged over 4 ft. long, minimum, nominal 1" x 2" pressure treated, decay resistant battens or galvanized metal batten. Battens shall be fastened to the sheathing with 3 - 8d ring shank (0.120 inch diameter) nails or screws per each 4 ft. long batten. When utilizing battens, tile headlap shall be a minimum of 3" inches unless restricted by product design and preformed flashings with metal edge returns shall be used.

For two piece barrel tiles only, for slopes above 6":12" up to and including 7":12" fasten every pan tile in the first course and every fifth course thereafter in addition to the tile adhesive. **Note: Some code bodies may require the eave tiles to be fastened at lower slopes.** For slopes above 7":12" fasten every tile (cover and pan tile) shall receive one fastener in addition to the tile adhesive. For attachment of cover tiles, on pitches above 7":12", the use of wood stringers under the cover tiles are optional. As an alternative, the use of galvanized, stainless steel, or copper wire and/ or compatible fastener or a straw nail (gutter spike) is also an acceptable option. Apply compatible flashing cement to seal all fastener penetrations where required. Some modified bitumen self-adhered membranes, have sealing capabilities. Contact the underlayment manufacturer for sealing capabilities of the specific waterproofing membrane. Fasteners shall be corrosion-resistant, (ASTM A641, class 1 or approved equal), of sufficient length to penetrate the deck a minimum of 3/4" or through the thickness of the deck, whichever is less.

COMMENTS AND LIMITATIONS

1. POLYPRO® AH-160 Roof Tile Adhesive shall be applied over a underlayment installed in compliance with the underlayment fastening tables as listed in our evaluation/compliance reports or the FRSA/TRI Concrete and Clay Roof Tile Installation Manual. (Visit our website www.polyfoam.cc for current approved underlayments.)
2. Installation must be by a factory trained "Qualified Applicator" approved and licensed by Polyfoam Products, Inc.
3. Test paddys must be shot at least every other course of tile and quality of adhesive verified.
4. Calibration of the FOAMPRO® dispensing equipment is required before application of any adhesive. The mix ratio of the "A" component and the "B" component shall be maintained between 1.0 -1.15 (A) to (B). For Ratio Calibration: Take the net weight of the "A" chemical and divide it by the net weight of the "B" chemical.
5. PROPACK® dispensing systems are pre-pressurized in the factory; however temperature and extended and or improper adhesive dispenser usage will effect the ratio calibration of the dispensed adhesive. **Note: Polyfoam Products, Inc. strongly suggests verifying the calibration of the Propack units. This can be accomplished by weighing the chemical as indicated in item #4 above or by thorough examination of the test paddys required in item #3. Contact Polyfoam**

Products, Inc. for detailed instructions. (888) 774-1099.

6. Adhesive shall be placed in accordance with our “paddy placement details” as mentioned in our evaluation or compliance reports.
7. Underlayment, Tile and Hip and Ridge support members must be dry, clean, free from any dust, debris, or oil or any foreign matter that will inhibit the bond of the adhesive.
8. Adhere tile directly in freshly applied adhesive. Tile must be set prior to adhesive “skinning over” usually 1 - 2 minutes depending on the ambient temperature.
9. POLYPRO® AH-160 Roof Tile Adhesive shall not be exposed permanently to ultra-violet rays (sunlight). Any exposed foam may be cut away and covered with mortar or coated with a good quality acrylic paint or paint designed for the application to polyurethane foam.
10. POLYPRO® AH-160 Roof Tile Adhesive shall be applied with Polyfoam Products dispensing equipment only.

- SEE FOLLOWING PAGES FOR PADDY PLACEMENT ILLUSTRATIONS -

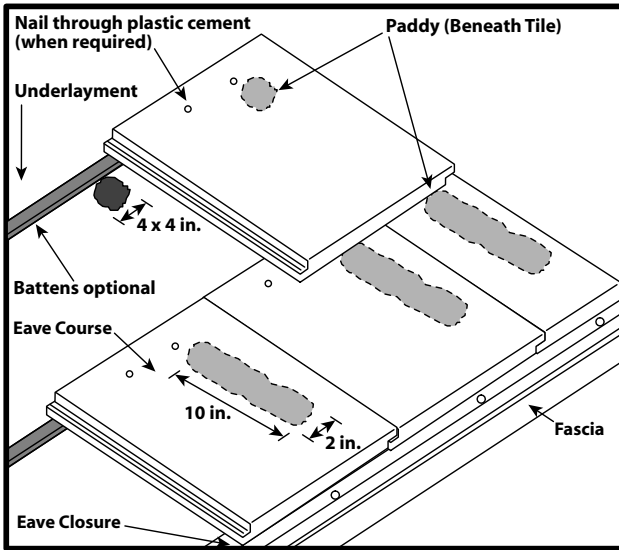

Flat/Low Profile Tile

Flat/Low Profile Tile

1. Starting at the eave course, apply a minimum 2" (50.8 mm) x 10" (254 mm) x 1" (25.4 mm) foam paddy onto the underlayment positioned as shown under the strengthening rib closest to the overlock of the tile being set. Insure approximately 17 (109.7 cm²) – 23 (148.4 cm²) square inch adhesive contact with the underside of the tile.
2. At the second course, apply a minimum 4" (101.6 mm) x 4" (101.6 mm) x 1" (25.4 mm) foam paddy onto the underlayment positioned as shown under the strengthening rib of the tile closest to the overlock of the tile being set.
3. Continue in same manner. Insure approximately 8 (51.6 cm²) - 9 (58.1 cm²) square inch adhesive contact with the underside of the tile.

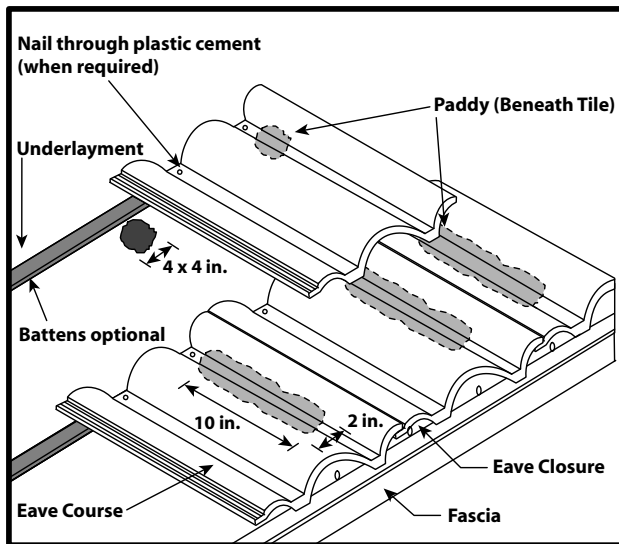

Medium Profile Tile

Medium Profile / Double Pan Tile

1. Starting at the eave course, apply a minimum 2" (50.8 mm) x 10" (254 mm) x 1" (25.4 mm) foam paddy onto the underlayment positioned as shown under the pan portion of the tile closest to the overlock of the tile being set. Insure approximately 17 (109.7 cm²) – 23 (148.4 cm²) square inch adhesive contact with the underside of the tile.
2. At the second course, apply a minimum 4" (101.6 mm) x 4" (101.6 mm) x 1" (25.4 mm) foam paddy onto the underlayment positioned as shown under the pan portion of the tile closest to the overlock of the tile being set.
3. Continue in same manner. Insure approximately 8 (51.6 cm²) - 9 (58.1 cm²) square inch adhesive contact with the underside of the tile.

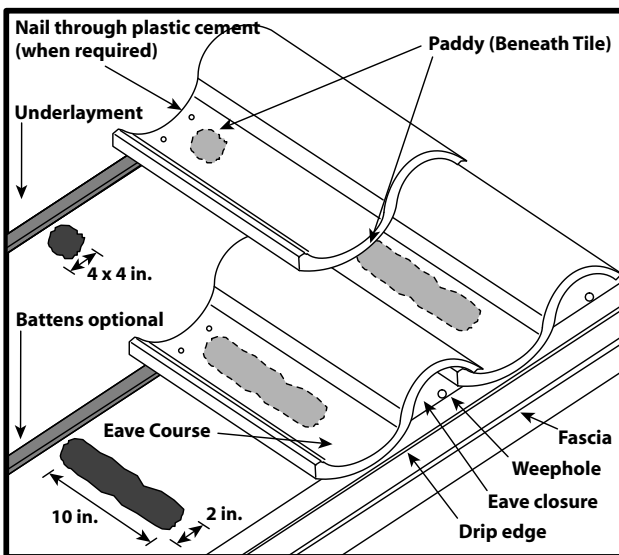

High Profile Tile

High Profile / Single Pan Tile

1. Starting at the eave course, apply a minimum 2" (50.8 mm) x 10" (254 mm) x 1" (25.4 mm) foam paddy onto the underlayment positioned as shown under the pan portion of the tile closest to the overlock of the tile being set. Insure approximately 17 (109.7 cm²) – 23 (148.4 cm²) square inch adhesive contact with the underside of the tile.
2. At the second course, apply a minimum 4" (101.6 mm) x 4" (101.6 mm) x 1" (25.4 mm) foam paddy onto the underlayment positioned as shown under the pan portion of the tile closest to the overlock of the tile being set.
3. Continue in same manner. Insure approximately 8 (51.6 cm²) - 9 (58.1 cm²) square inch adhesive contact with the underside of the tile.

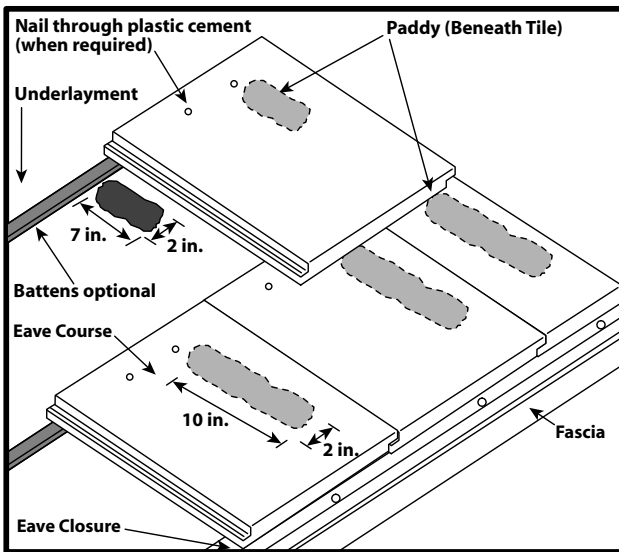

Flat/Low Profile Tile

Flat/Low Profile Tile

1. Starting at the eave course, apply a minimum 2" (50.8 mm) x 10" (254 mm) x 1" (25.4 mm) foam paddy onto the underlayment positioned as shown under the strengthening rib of the tile closest to the overlock of the tile being set. Insure approximately 17 (109.7 cm²) – 23 (148.4 cm²) square inch adhesive contact with the underside of the tile.
2. At the second course, apply a minimum 2" (50.8mm) x 7" (177.8 mm) x 1" (25.4 mm) foam paddy onto the underlayment positioned as shown under the strengthening rib closest to the overlock of the tile being set.
3. Continue in same manner. Insure approximately 10" (64.5 cm²) - 12 (77.4 cm²) square inch adhesive contact with the underside of the tile.

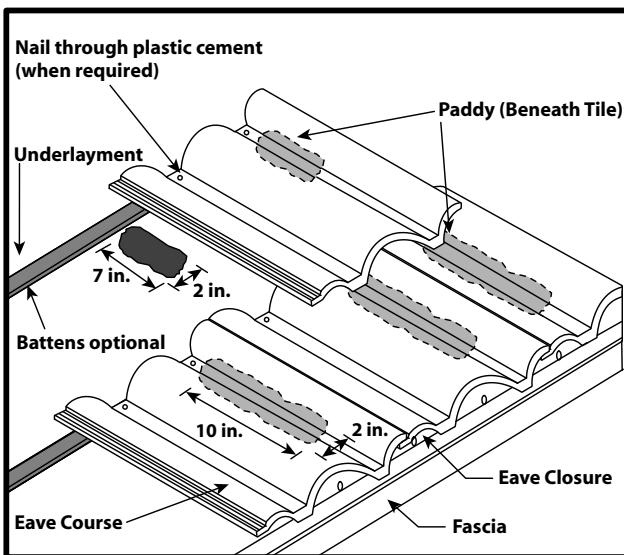

Medium Profile Tile

Medium Profile / Double Pan Tile

1. Starting at the eave course, apply a minimum 2" (50.8 mm) x 10" (254 mm) x 1" (25.4 mm) foam paddy onto the underlayment positioned as shown under the pan portion of the tile closest to the overlock of the tile being set. Insure approximately 17 (109.7 cm²) – 23 (148.4 cm²) square inch adhesive contact with the underside of the tile.
2. At the second course, apply a minimum 2" (50.8mm) x 7" (177.8 mm) x 1" (25.4 mm) foam paddy onto the underlayment positioned as shown under the pan portion of the tile closest to the overlock of the tile being set.
3. Continue in same manner. Insure approximately 12" (77.4 cm²) - 14 (90.3 cm²) square inch adhesive contact with the underside of the tile.

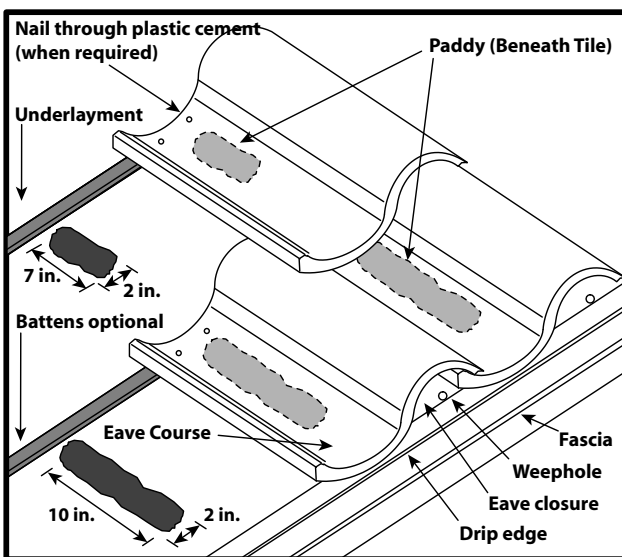

High Profile Tile

High Profile / Single Pan Tile

1. Starting at the eave course, apply a minimum 2" (50.8 mm) x 10" (254 mm) x 1" (25.4 mm) foam paddy onto the underlayment positioned as shown under the pan portion of the tile closest to the overlock of the tile being set. Insure approximately 17 (109.7 cm²) – 23 (148.4 cm²) square inch adhesive contact with the underside of the tile.
2. At the second course, apply a minimum 2" (50.8mm) x 7" (177.8 mm) x 1" (25.4 mm) foam paddy onto the underlayment positioned as shown under the pan portion of the tile closest to the overlock of the tile being set.
3. Continue in same manner. Insure approximately 17" (109.7 cm²) - 19 (122.6 cm²) square inch adhesive contact with the underside of the tile.

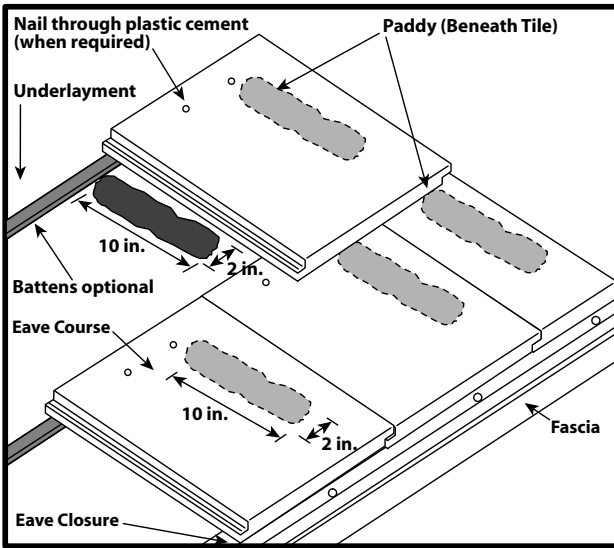

Flat/Low Profile Tile

Flat/Low Profile Tile

1. Starting at the eave course, apply a minimum 2" (50.8 mm) x 10" (254 mm) x 1" (25.4 mm) foam paddy onto the underlayment positioned as shown, under the strengthening rib closest to the overlock of the tile being set.
2. Continue in same manner. Insure approximately 17 (109.7 cm²) – 23 (148.4 cm²) square inch adhesive contact with the underside of the tile.

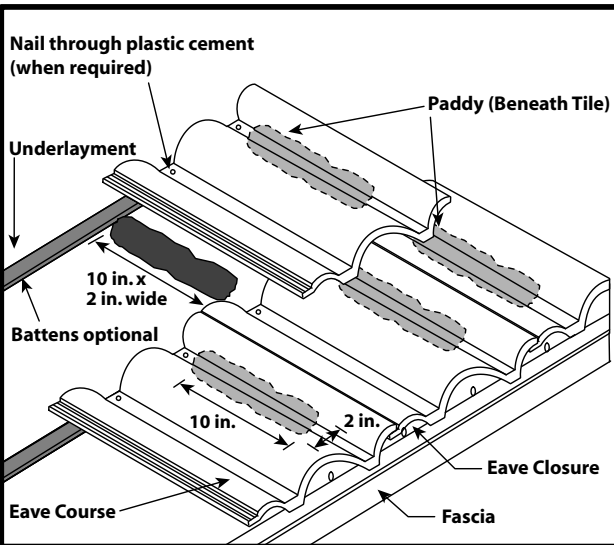

Medium Profile Tile

Medium Profile / Double Pan Tile

1. Starting at the eave course, apply a minimum 2" (50.8 mm) x 10" (254 mm) x 1" (25.4 mm) foam paddy onto the underlayment positioned as shown under the pan portion of the tile closest to the overlock of the tile being set.
2. Continue in same manner. Insure approximately 17 (109.7 cm²) – 23 (148.4 cm²) square inch adhesive contact with the underside of the tile.

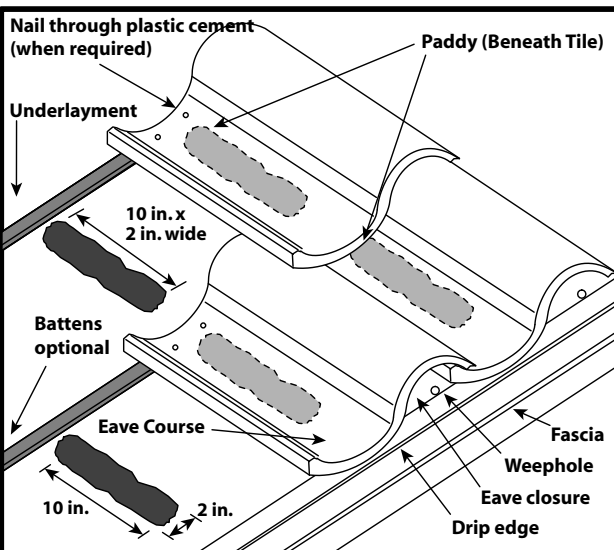

High Profile Tile

High Profile / Single Pan Tile

- 1). Starting at the eave course, apply a minimum 2" (50.8 mm) x 10" (254 mm) x 1" (25.4 mm) foam paddy onto the underlayment positioned as shown under the pan portion of the tile closest to the overlock of the tile being set.
2. Continue in same manner. Insure approximately 17 (109.7 cm²) – 23 (148.4 cm²) square inch adhesive contact with the underside of the tile.

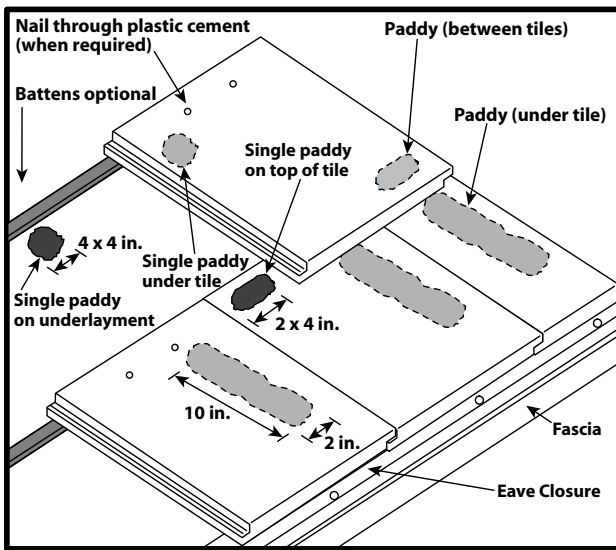

Flat/Low Profile Tile

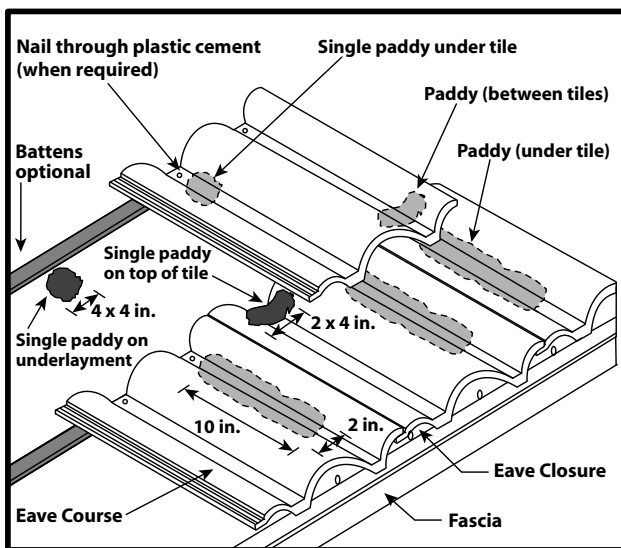

Medium Profile Tile

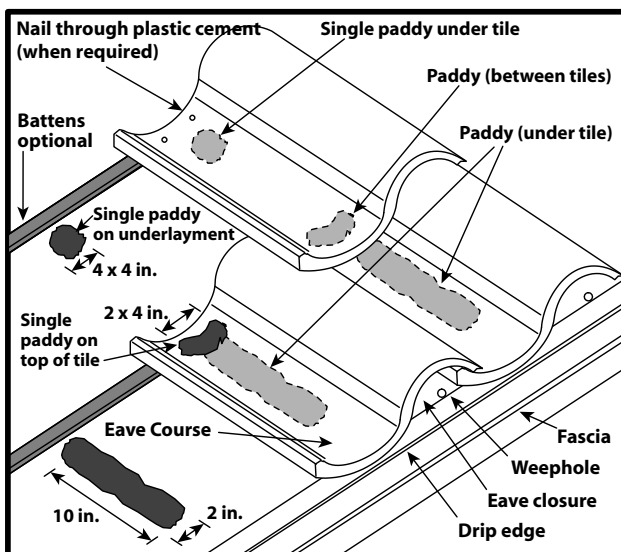

High Profile Tile

1. On the eave course only, apply a minimum 2" (50.8 mm) x 10" (254 mm) x 1" (25.4 mm) foam paddy onto the underlayment positioned as shown, under the strengthening rib for flat tile, or under the pan portion of the tile for medium or high profile tile closest to the overlock of the tile being set. Leave approximately 4" (101.6 mm) up from the eave edge free of foam to prevent the expanded adhesive from blocking the weep holes. Insure approximately 17 (109.7 cm²) – 23 (148.4 cm²) square inch adhesive contact with the underside of the tile.
2. Apply a 4" (101.6 mm) x 4" (101.6 mm) x 1" (25.4 mm) foam paddy onto the underlayment just below the first course line positioned foam paddy under the strengthening rib for flat tile, or under the pan position of the tile, closest to the underlock of the eave tile to be installed. Install eave course of tile. Insure approximately 8 (51.6 cm²) - 9 (58.1 cm²) square inches of adhesive contact with the underside of the tile.
3. Apply a 4" (101.6 mm) x 4" (101.6 mm) x 1" (25.4 mm) foam paddy onto the underlayment just below the second course line positioned foam paddy under the strengthening rib for flat tile, or under the pan portion of the tile, closest to the underlock for the second course tile to be installed.
4. Also apply a 2" (50.8 mm) x 4" (101.6 mm) x 3/4" (19 mm) paddy on top of the eave course tile surface as shown, on top of the strengthening rib for flat tile, or on top of the pan portion of the tile, closest to the underlock of the first course of tile. Install second course of tile. Insure approximately 9 (58.1 cm²) - 11 (71 cm²) square inches of adhesive contact with the underside of the tile at the overlap and 8 (51.6 cm²) - 9 (58.1 cm²) square inches of adhesive contact with the underside of the tile at the head of the tile. Continue in same manner.

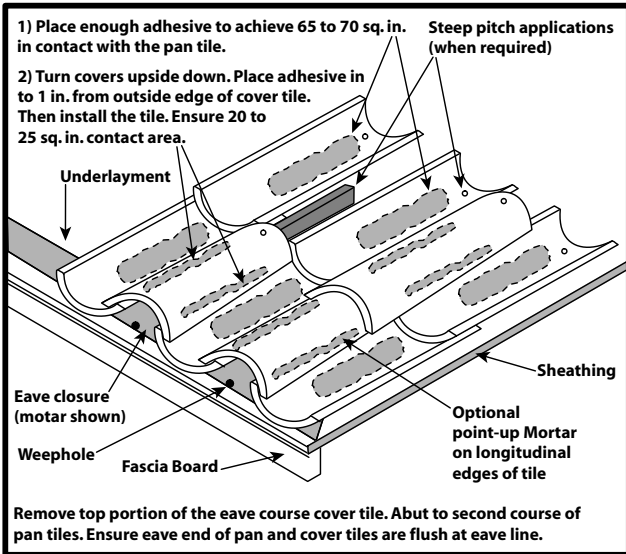

Two Piece Barrel - High Profile Tile

Two Piece Barrel (Cap and Pan) Tile

1. Starting at the eave course, apply a minimum 2" (50.8 mm) x 10" (254 mm) x 1" (25.4 mm) foam paddy onto the underlayment positioned as shown under two adjacent pan tiles. Support eave tiles from rocking until adhesive has a chance to cure.
2. Continue in same manner bringing two pan courses up toward the ridge. Insure approximately 65 (419.4 cm²) - 70 (451.6 cm²) square inch adhesive contact with the underside of the pan tile.
3. Turn covers upside down exposing the underside of the tile. Apply a minimum 1" (25.4 mm) x 10" (254 mm) bead of adhesive directly on the inner edge of each side of the cover tile. Leave approximately 3/4" (19 mm) to 1" (25.4 mm) from the outside edge of the tile, inward, free of foam to allow for expansion.
4. Turn cover tile over after foam is applied and place onto pan tile course. Insure a minimum of 20 (129 cm²) - 25 (161.3 cm²) square inch contact area on each side of the cover tile to the pan tile. Continue in same manner. Trim away any cured exposed foam adhesive. Pointing of longitudinal edges of the cover tiles are considered optional.
5. When additional nailing is required, 2" (50.8 mm) x 4" (101.6 mm) nailers or the tie wire system using galvanized, stainless steel, or copper wire and compatible nails may be used.



SMALL PADDY

4" x 4" x 1"

(101.6 mm x 101.6 mm x 25.4 mm)



MEDIUM PADDY

2" x 7" x 1"

(50.8 mm x 177.8 mm x 25.4 mm)

PADDY CONFIGURATIONS

- Actual Size -

The drawings on this page show the ideal paddy size and shape as initially applied wet to the roof deck. The foam adhesive will expand after application to the roof deck and will conform to the space between the underside of the roof tile and roof surface after the tile has been placed.



LARGE PADDY

2" x 10" x 1"

(50.8 mm x 254 mm x 25.4 mm)

PADDY SIZES